

# ML-SM-150C-D-3

includes  
150 Watt CMH Projector, and Rack Mounting with Attached Ballast

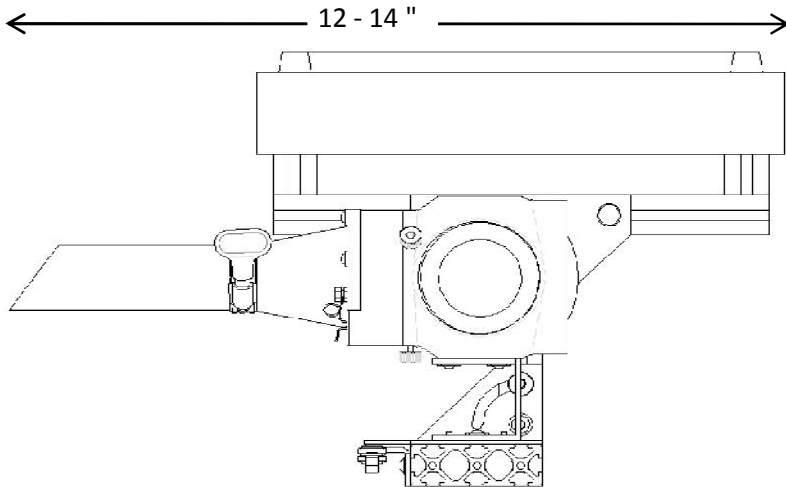
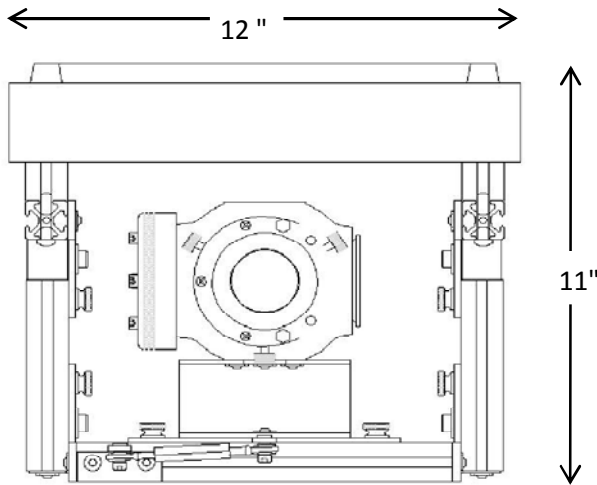

## Projector Specifications

Description	Merlin Light® Precision optical framing projector
Catalog #	ML-SM-150C-D-3
Application	Surface mount for all models of Merlin Light where an exposed projector is desired.
Lamp & Base	150 Watt Ceramic Metal Halide Lamp L3-A
Attached Ballast	150 Watt Ceramic Metal Halide Lamp and 150W, 120/277 VAC electronic ballast, dimmable to 50%. Time delay on hot restart.
See wiring detail sheet	0-10V wiring and interface required for dimming
Projector P1	Cast aluminum body with black anodize finish. Projector will be supplied and installed by a GlennCo Inc. or factory certified technician. Installer will make final installation and confinement on art object being illuminated.
Mounting M2	Rack Mount
Lens	Objective lens selected by installation technician.



652 W. Confluence Ave Murray Utah, 84123

385-743-3333 fax 385-743-3334

www.glenncoinc.com

\* Copyright Protected, GlennCo INC. 2006

