

# ML-SM-250I-D-2

includes  
250 Watt CMH Projector, and Rack Mounting

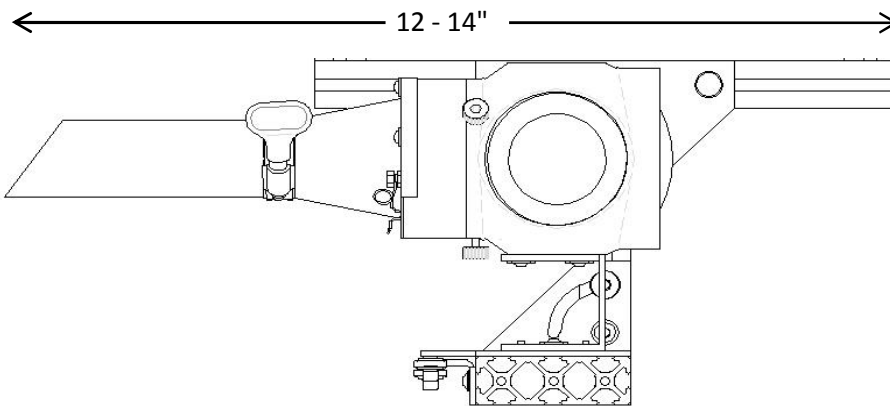
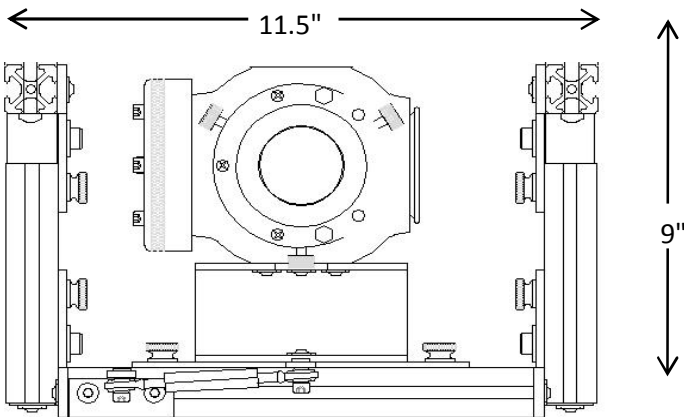

## Projector Specifications

Description	Merlin Light® Precision optical framing projector
Catalog #	ML-SM-250I-D-2
Application	Surface mount for all models of Merlin Light where an exposed projector is desired.
Lamp & Base	120 V power, 150 or 250 Watt Halogen Lamp.
L1	100% Dimmable
See wiring detail sheet	
Projector P1	Cast aluminum body with black anodize finish. Projector will be supplied and installed by a GlennCo Inc. or factory certified technician. Installer will make final installation and confinement on art object being illuminated.
Mounting M2	Rack Mount
Lens	Objective lens selected by installation technician.



652 W. Confluence Ave Murray Utah, 84123

385-743-3333 fax 385-743-3334

www.glenncoinc.com

\* Copyright Protected, GlennCo INC. 2006

